



Compressor
Voltage Code : XG

FH4524Z-XG

High Temp. Commercial (HP)

380-420V 3~ 50Hz / 460V 3~ 60 Hz

R452A / R404A / R448A / R449A

FH4524Z-XG1A

Conditions	Frequency	Nominal Cooling Capacity		Sound Power ISO3745 / ISO 3743-1
		Watts	BTU/h	
EN12900_MHP / R452A	50 Hz / 60 Hz	2854 / 3493	9732 / 11910	71 dBA
EN12900_MHP / R404A	50 Hz / 60 Hz	2941 / 3599	10030 / 12273	71 dBA
EN12900_MHP / R448A	50 Hz / 60 Hz	2714 / 3323	9256 / 11330	71 dBA
EN12900_MHP / R449A	50 Hz / 60 Hz	2714 / 3323	9256 / 11330	71 dBA

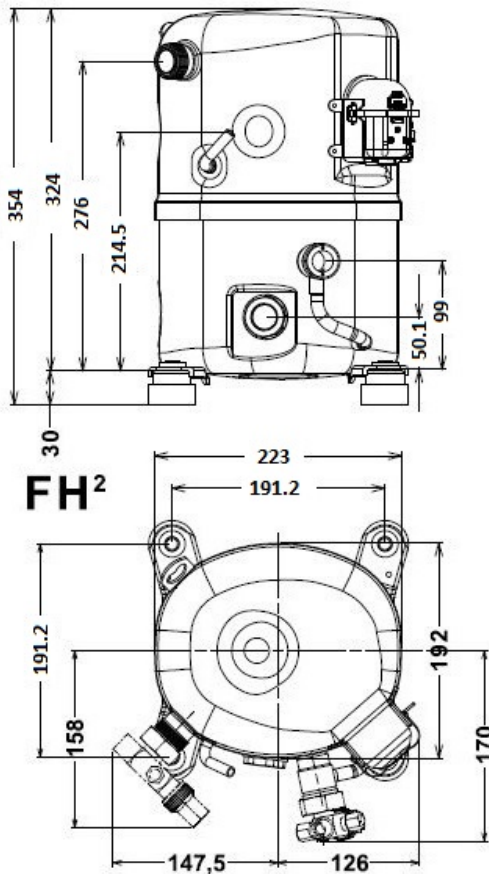

Displacement (cc)	43,3
Net Weight (Kg)	33.0
Oil Quantity (cc)	1140.0
Oil Type	Polyolester
Expansion Device	Capillary_Tube/Expansion_Valve
Cooling	Fan
Main Winding (Ohm)	7.05
Current	
RLA (A)	3.8 3.9
MCC (A)	6.6
LRA (A)	26
Electrical Equipment	TRI
Overload	Interne
Refrigerating connection for	
Suction Tube	15.9 (5/8")
Discharge Tube	12.7 (1/2")
Process Tube	6.35 (1/4")

* EN12900_MHP : T°Cond. 45.0°C / T°Evap. -10.0°C / T°Return gas temp.. 20.0°C
T°Subcooling. 0.0K

Certificates :

Note : Tecumseh reserves the right to change information contained in this document without notification.

Selection program - V4.6_2024205 - 07/28/2024



Tecumseh

FH4524Z-XG	Tension XG : 380-420V 3~ 50Hz / 460V 3~ 60 Hz
-------------------	--

Les performances sont données dans les **conditions EN12900_MHP** :
 Condition Dew
 The performance data are in **EN12900_MHP conditions** :
 Dew Condition

Gaz aspirés : 20.0 °C
 Sous refroidissement : 0.0 K
 Return gas : 20.0 °C
 Subcooling : 0.0 K

50 Hz R452A											
											N°User-226
4 T condensation	5 T évaporation	(°C)	-25	-20	-15	-10	-5	0	5	10	15
30	1 P frigorifique	(Watt)	1704	2370	3162	4098	5198	6480	7962	9664	11605
	2 P absorbée	(W)	876	1056	1208	1334	1434	1509	1558	1584	1586
	3 I absorbée	(A)	1.95	2.18	2.38	2.54	2.68	2.79	2.88	2.95	3.01
40	1 P frigorifique	(Watt)		1770	2459	3261	4193	5276	6527	7965	9610
	2 P absorbée	(W)		1026	1232	1411	1562	1687	1786	1860	1909
	3 I absorbée	(A)		2.14	2.41	2.66	2.87	3.04	3.20	3.32	3.43
50	1 P frigorifique	(Watt)			1785	2456	3226	4114	5139	6318	7672
	2 P absorbée	(W)			1206	1440	1645	1823	1974	2098	2196
	3 I absorbée	(A)			2.37	2.70	2.99	3.25	3.47	3.67	3.84
60	1 P frigorifique	(Watt)				1691	2303	3001	3804	4729	5796
	2 P absorbée	(W)				1420	1682	1915	2120	2297	2446
	3 I absorbée	(A)				2.65	3.04	3.38	3.69	3.96	4.20

60 Hz R452A											
											N°User-226
4 T condensation	5 T évaporation	(°C)	-25	-20	-15	-10	-5	0	5	10	15
30	1 P frigorifique	(Watt)	2000	2881	3884	5031	6343	7842	9550	11488	13678
	2 P absorbée	(W)	1065	1283	1469	1622	1743	1834	1895	1926	1928
	3 I absorbée	(A)	1.95	2.19	2.39	2.56	2.70	2.81	2.90	2.97	3.03
40	1 P frigorifique	(Watt)		2085	2995	4013	5161	6461	7935	9604	11490
	2 P absorbée	(W)		1247	1498	1715	1899	2051	2172	2261	2321
	3 I absorbée	(A)		2.14	2.43	2.67	2.88	3.06	3.21	3.34	3.45
50	1 P frigorifique	(Watt)			2098	2974	3945	5033	6260	7647	9215
	2 P absorbée	(W)			1466	1750	2000	2216	2399	2550	2669
	3 I absorbée	(A)			2.39	2.72	3.01	3.27	3.49	3.69	3.86
60	1 P frigorifique	(Watt)				1967	2748	3611	4577	5669	6907
	2 P absorbée	(W)				1727	2045	2328	2577	2792	2974
	3 I absorbée	(A)				2.67	3.06	3.41	3.71	3.99	4.24

1 = cooling capacity 2 = power input 3 = current 4 = condensing temperature 5 = evaporating temperature

Nota : Tecumseh se réserve le droit de modifier les informations contenues dans ce document sans préavis.
Note : Tecumseh reserves the right to change information contained in this document without notification.

© 2024 Tecumseh Products Company
All rights reserved



Tecumseh

FH4524Z-XG	Tension XG : 380-420V 3~ 50Hz / 460V 3~ 60 Hz
-------------------	--

Les performances sont données dans les **conditions EN12900_MHP** :
 Condition Dew
 The performance data are in **EN12900_MHP conditions** :
 Dew Condition

Gaz aspirés : 20.0 °C
 Sous refroidissement : 0.0 K
 Return gas : 20.0 °C
 Subcooling : 0.0 K

50 Hz R404A											
											N°User-225
4 T condensation	5 T évaporation	(°C)	-25	-20	-15	-10	-5	0	5	10	15
30	1 P frigorifique	(Watt)	1837	2500	3293	4231	5332	6614	8096	9793	11723
	2 P absorbée	(W)	938	1124	1280	1406	1502	1568	1602	1605	1575
	3 I absorbée	(A)	2.09	2.32	2.52	2.68	2.81	2.90	2.96	2.99	2.98
40	1 P frigorifique	(Watt)	1301	1888	2570	3363	4285	5354	6587	8001	9615
	2 P absorbée	(W)	857	1094	1303	1484	1635	1757	1848	1909	1939
	3 I absorbée	(A)	1.97	2.28	2.55	2.79	3.00	3.17	3.31	3.41	3.49
50	1 P frigorifique	(Watt)		1296	1873	2528	3277	4138	5129	6266	7569
	2 P absorbée	(W)		1026	1285	1516	1720	1894	2040	2156	2242
	3 I absorbée	(A)		2.17	2.52	2.84	3.13	3.37	3.59	3.77	3.92
60	1 P frigorifique	(Watt)			1209	1731	2314	2973	3728	4595	5593
	2 P absorbée	(W)			1236	1516	1768	1993	2190	2359	2498
	3 I absorbée	(A)			2.44	2.83	3.19	3.52	3.81	4.07	4.29

60 Hz R404A											
											N°User-225
4 T condensation	5 T évaporation	(°C)	-25	-20	-15	-10	-5	0	5	10	15
30	1 P frigorifique	(Watt)	2155	3039	4044	5194	6507	8005	9709	11639	13817
	2 P absorbée	(W)	1141	1366	1556	1709	1826	1906	1948	1951	1915
	3 I absorbée	(A)	2.09	2.33	2.53	2.70	2.83	2.92	2.98	3.01	3.01
40	1 P frigorifique	(Watt)	1406	2225	3129	4139	5275	6558	8008	9647	11495
	2 P absorbée	(W)	1042	1330	1585	1804	1988	2136	2247	2321	2357
	3 I absorbée	(A)	1.97	2.29	2.57	2.81	3.01	3.18	3.32	3.43	3.50
50	1 P frigorifique	(Watt)		1410	2202	3060	4007	5063	6248	7584	9092
	2 P absorbée	(W)		1247	1562	1843	2090	2303	2480	2621	2726
	3 I absorbée	(A)		2.18	2.54	2.86	3.15	3.40	3.61	3.79	3.94
60	1 P frigorifique	(Watt)			1318	2014	2760	3578	4487	5508	6663
	2 P absorbée	(W)			1503	1843	2150	2423	2663	2867	3037
	3 I absorbée	(A)			2.46	2.85	3.22	3.54	3.84	4.10	4.33

1 = cooling capacity 2 = power input 3 = current 4 = condensing temperature 5 = evaporating temperature

Nota : Tecumseh se réserve le droit de modifier les informations contenues dans ce document sans préavis.
Note : Tecumseh reserves the right to change information contained in this document without notification.

© 2024 Tecumseh Products Company
All rights reserved



Tecumseh

FH4524Z-XG	Tension XG : 380-420V 3~ 50Hz / 460V 3~ 60 Hz
-------------------	--

Les performances sont données dans les **conditions EN12900_MHP** :
 Condition Dew
 The performance data are in **EN12900_MHP conditions** :
 Dew Condition

Gaz aspirés : 20.0 °C
 Sous refroidissement : 0.0 K
 Return gas : 20.0 °C
 Subcooling : 0.0 K

50 Hz R448A (*)											
											N°User-228
4 T condensation	5 T évaporation	(°C)	-25	-20	-15	-10	-5	0	5	10	15
30	1 P frigorifique	(Watt)	1518	2142	2899	3809	4893	6171	7665	9395	11382
	2 P absorbée	(W)	826	991	1134	1254	1348	1416	1454	1463	1439
	3 I absorbée	(A)	1.84	2.05	2.23	2.39	2.52	2.62	2.69	2.73	2.73
40	1 P frigorifique	(Watt)		1628	2288	3072	4002	5097	6378	7867	9585
	2 P absorbée	(W)		969	1159	1328	1472	1591	1683	1746	1779
	3 I absorbée	(A)		2.02	2.27	2.50	2.70	2.87	3.01	3.12	3.20
50	1 P frigorifique	(Watt)			1698	2366	3149	4069	5147	6403	7858
	2 P absorbée	(W)			1145	1363	1558	1729	1875	1994	2084
	3 I absorbée	(A)			2.25	2.56	2.83	3.08	3.30	3.49	3.64
60	1 P frigorifique	(Watt)				1702	2347	3101	3983	5014	6216
	2 P absorbée	(W)				1363	1610	1834	2035	2210	2357
	3 I absorbée	(A)				2.55	2.91	3.24	3.54	3.81	4.05

60 Hz R448A (*)											
											N°User-228
4 T condensation	5 T évaporation	(°C)	-25	-20	-15	-10	-5	0	5	10	15
30	1 P frigorifique	(Watt)	1780	2603	3561	4676	5971	7469	9194	11168	13415
	2 P absorbée	(W)	1004	1205	1379	1524	1639	1721	1768	1778	1750
	3 I absorbée	(A)	1.84	2.06	2.25	2.41	2.54	2.64	2.70	2.74	2.75
40	1 P frigorifique	(Watt)		1917	2786	3782	4926	6243	7755	9486	11458
	2 P absorbée	(W)		1178	1409	1614	1790	1934	2046	2123	2163
	3 I absorbée	(A)		2.03	2.28	2.51	2.71	2.88	3.02	3.14	3.21
50	1 P frigorifique	(Watt)			1997	2865	3851	4978	6269	7749	9438
	2 P absorbée	(W)			1392	1657	1894	2103	2280	2424	2533
	3 I absorbée	(A)			2.27	2.57	2.85	3.10	3.32	3.51	3.67
60	1 P frigorifique	(Watt)				1981	2800	3729	4792	6011	7410
	2 P absorbée	(W)				1657	1957	2230	2474	2686	2866
	3 I absorbée	(A)				2.57	2.93	3.26	3.57	3.84	4.08

1 = cooling capacity 2 = power input 3 = current 4 = condensing temperature 5 = evaporating temperature

(*) Veuillez vous référer strictement aux Recommandations d'Utilisation et Bulletins Marketing Tecumseh du fait de la température de refoulement élevée pour les applications LBP.
 (*) Due to very high discharge temperature especially on LBP conditions, please strictly refer to Tecumseh Guidelines & Marketing Bulletin when using this refrigerant.

Nota : Tecumseh se réserve le droit de modifier les informations contenues dans ce document sans préavis.
Note : Tecumseh reserves the right to change information contained in this document without notification.

© 2024 Tecumseh Products Company
All rights reserved



Tecumseh

FH4524Z-XG	Tension XG : 380-420V 3~ 50Hz / 460V 3~ 60 Hz
-------------------	--

Les performances sont données dans les conditions EN12900_MHP :	Gaz aspirés :	20.0 °C
Condition Dew	Sous refroidissement :	0.0 K
The performance data are in EN12900_MHP conditions :	Return gas :	20.0 °C
Dew Condition	Subcooling :	0.0 K

© 2024 Tecumseh Products Company
All rights reserved

50 Hz R449A (*)

N°User-227

4 T condensation	5 T évaporation	(°C)	-25	-20	-15	-10	-5	0	5	10	15
30	1 P frigorifique	(Watt)	1518	2142	2899	3809	4893	6171	7665	9395	11382
	2 P absorbée	(W)	826	991	1134	1254	1348	1416	1454	1463	1439
	3 I absorbée	(A)	1.84	2.05	2.23	2.39	2.52	2.62	2.69	2.73	2.73
40	1 P frigorifique	(Watt)		1628	2288	3072	4002	5097	6378	7867	9585
	2 P absorbée	(W)		969	1159	1328	1472	1591	1683	1746	1779
	3 I absorbée	(A)		2.02	2.27	2.50	2.70	2.87	3.01	3.12	3.20
50	1 P frigorifique	(Watt)			1698	2366	3149	4069	5147	6403	7858
	2 P absorbée	(W)			1145	1363	1558	1729	1875	1994	2084
	3 I absorbée	(A)			2.25	2.56	2.83	3.08	3.30	3.49	3.64
60	1 P frigorifique	(Watt)				1702	2347	3101	3983	5014	6216
	2 P absorbée	(W)				1363	1610	1834	2035	2210	2357
	3 I absorbée	(A)				2.55	2.91	3.24	3.54	3.81	4.05

60 Hz R449A (*)

N°User-227

4 T condensation	5 T évaporation	(°C)	-25	-20	-15	-10	-5	0	5	10	15
30	1 P frigorifique	(Watt)	1780	2603	3561	4676	5971	7469	9194	11168	13415
	2 P absorbée	(W)	1004	1205	1379	1524	1639	1721	1768	1778	1750
	3 I absorbée	(A)	1.84	2.06	2.25	2.41	2.54	2.64	2.70	2.74	2.75
40	1 P frigorifique	(Watt)		1917	2786	3782	4926	6243	7755	9486	11458
	2 P absorbée	(W)		1178	1409	1614	1790	1934	2046	2123	2163
	3 I absorbée	(A)		2.03	2.28	2.51	2.71	2.88	3.02	3.14	3.21
50	1 P frigorifique	(Watt)			1997	2865	3851	4978	6269	7749	9438
	2 P absorbée	(W)			1392	1657	1894	2103	2280	2424	2533
	3 I absorbée	(A)			2.27	2.57	2.85	3.10	3.32	3.51	3.67
60	1 P frigorifique	(Watt)				1981	2800	3729	4792	6011	7410
	2 P absorbée	(W)				1657	1957	2230	2474	2686	2866
	3 I absorbée	(A)				2.57	2.93	3.26	3.57	3.84	4.08

1 = cooling capacity 2 = power input 3 = current 4 = condensing temperature 5 = evaporating temperature

(*) Veuillez vous référer strictement aux Recommandations d'Utilisation et Bulletins Marketing Tecumseh du fait de la température de refoulement élevée pour les applications LBP.

(*) Due to very high discharge temperature especially on LBP conditions, please strictly refer to Tecumseh Guidelines & Marketing Bulletin when using this refrigerant.

Nota : Tecumseh se réserve le droit de modifier les informations contenues dans ce document sans préavis.

Note : Tecumseh reserves the right to change information contained in this document without notification.