



Compressor
Voltage Code : HZ

CAJ9480Z-HZ

High Temp. Commercial (MHP)

208 - 220V 1~ 60 Hz

R452A / R404A / R449A

AJK480Z-HZ3C

Conditions	Frequency	Nominal Cooling Capacity		Sound Power ISO3745 / ISO 3743-1
		Watts	BTU/h	
EN12900_HP / R452A	60 Hz	2336	7965	66 dBA
EN12900_HP / R404A	60 Hz	2332	7953	66 dBA
EN12900_HP / R449A	60 Hz	2338	7972	66 dBA

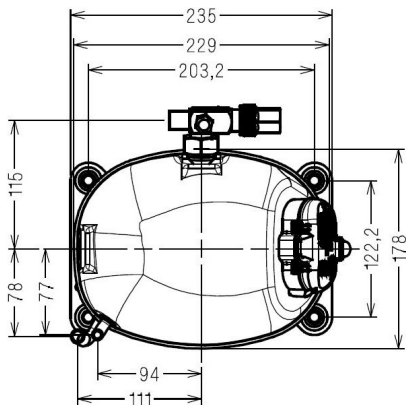
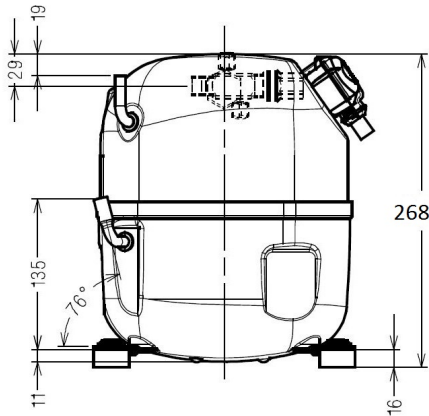

Displacement (cc)	15,2
Net Weight (Kg)	21.0
Oil Quantity (cc)	475.0
Oil Type	Polyolester
Expansion Device	Capillary_Tube/Expansion_Valve
Cooling	Fan
Main Winding (Ohm)	2.1
Start Winding (Ohm)	8.9
Current	
RLA (A)	5.8
MCC (A)	8.5
LRA (A)	26
Electrical Equipment	CSR
Overload	MRA38088
Time Check	2.8s - 5.2s / 27.5 A
Open Temp	105° C
Close Temp	57° C
Optional	T0419
Start Capacitor	72 µF / 250 V
Run Capacitor	15 µF / 400 V
Potential Relay	RVA4AL**
Pick Up	223/252V
Drop Out	60/121V
Optional	3ARR3*6V*
Refrigerating connection for	
Suction Tube	12.7 (1/2")
Discharge Tube	7.9 (5/16")
Process Tube	6.35 (1/4")

* EN12900_HP : T°Cond. 50.0°C / T°Evap. 5.0°C / T°Return gas temp.. 20.0°C
T°Subcooling. 0.0K

Certificates :



Note : Tecumseh reserves the right to change information contained in this document without notification.

Selection program - V4.6_2023296 - 11/19/2023



Tecumseh

CAJ9480Z-HZ	Tension HZ : 208 - 220V 1~ 60 Hz
--------------------	---

Les performances sont données dans les **conditions EN12900_HP** :
 Condition Dew
 The performance data are in **EN12900_HP conditions** :
 Dew Condition

Gaz aspirés : 20.0 °C
 Sous refroidissement : 0.0 K
 Return gas : 20.0 °C
 Subcooling : 0.0 K

© 2023 Tecumseh Products Company
All rights reserved

60 Hz R452A

N°2713

4 T condensation	5 T évaporation	(°C)	-25	-20	-15	-10	-5	0	5	10	15
30	1 P frigorifique	(Watt)	956	1230	1553	1930	2360	2848	3395	4004	4676
	2 P absorbée	(W)	621	708	786	851	900	930	937	917	867
	3 I absorbée	(A)	2.85	3.11	3.36	3.62	3.89	4.17	4.46	4.75	5.05
40	1 P frigorifique	(Watt)	746	989	1273	1600	1973	2394	2865	3390	3969
	2 P absorbée	(W)	548	644	736	823	901	965	1014	1042	1047
	3 I absorbée	(A)	2.71	3.07	3.43	3.80	4.16	4.52	4.89	5.26	5.63
50	1 P frigorifique	(Watt)		758	1000	1276	1589	1942	2336	2774	3258
	2 P absorbée	(W)		618	722	826	928	1023	1108	1181	1237
	3 I absorbée	(A)		3.04	3.50	3.97	4.42	4.87	5.32	5.77	6.21
60	1 P frigorifique	(Watt)			730	953	1205	1487	1802	2152	2540
	2 P absorbée	(W)			715	833	954	1076	1195	1307	1410
	3 I absorbée	(A)			3.56	4.13	4.68	5.22	5.75	6.27	6.79

60 Hz R404A

N°224CT-HZ

4 T condensation	5 T évaporation	(°C)	-25	-20	-15	-10	-5	0	5	10	15
30	1 P frigorifique	(Watt)	1018	1299	1625	2000	2428	2912	3453	4052	4711
	2 P absorbée	(W)	657	747	826	892	940	968	971	947	891
	3 I absorbée	(A)	3.02	3.28	3.53	3.80	4.07	4.34	4.62	4.91	5.20
40	1 P frigorifique	(Watt)	799	1044	1325	1648	2015	2428	2890	3400	3958
	2 P absorbée	(W)	584	682	777	864	941	1004	1050	1075	1075
	3 I absorbée	(A)	2.89	3.26	3.62	3.98	4.35	4.71	5.06	5.42	5.78
50	1 P frigorifique	(Watt)		802	1038	1307	1611	1952	2332	2751	3206
	2 P absorbée	(W)		659	765	870	971	1065	1148	1217	1268
	3 I absorbée	(A)		3.24	3.71	4.17	4.63	5.07	5.51	5.94	6.36
60	1 P frigorifique	(Watt)			761	973	1211	1477	1772	2095	2441
	2 P absorbée	(W)			764	881	1002	1122	1238	1346	1444
	3 I absorbée	(A)			3.80	4.37	4.91	5.44	5.96	6.46	6.95

1 = cooling capacity 2 = power input 3 = current 4 = condensing temperature 5 = evaporating temperature

Nota : Tecumseh se réserve le droit de modifier les informations contenues dans ce document sans préavis.

Note : Tecumseh reserves the right to change information contained in this document without notification.



Tecumseh

CAJ9480Z-HZ	Tension HZ : 208 - 220V 1~ 60 Hz
--------------------	---

Les performances sont données dans les conditions EN12900_HP :	Gaz aspirés :	20.0 °C
Condition Dew	Sous refroidissement :	0.0 K
The performance data are in EN12900_HP conditions :	Return gas :	20.0 °C
Dew Condition	Subcooling :	0.0 K

60 Hz R449A (*)

N°3160

4 T condensation	5 T évaporation	(°C)	-25	-20	-15	-10	-5	0	5	10	15
30	1 P frigorifique	(Watt)	842	1110	1428	1800	2229	2718	3270	3888	4574
	2 P absorbée	(W)	578	658	732	796	844	874	882	863	815
	3 I absorbée	(A)	2.66	2.89	3.13	3.39	3.65	3.92	4.19	4.47	4.75
40	1 P frigorifique	(Watt)		898	1179	1507	1884	2314	2798	3341	3946
	2 P absorbée	(W)		604	690	773	847	910	956	983	986
	3 I absorbée	(A)		2.88	3.22	3.56	3.91	4.26	4.61	4.96	5.30
50	1 P frigorifique	(Watt)			942	1225	1550	1920	2338	2806	3328
	2 P absorbée	(W)			682	781	880	972	1055	1125	1178
	3 I absorbée	(A)			3.31	3.75	4.20	4.63	5.07	5.49	5.91
60	1 P frigorifique	(Watt)				957	1229	1539	1890	2283	2723
	2 P absorbée	(W)				792	912	1033	1151	1262	1362
	3 I absorbée	(A)				3.92	4.47	5.01	5.54	6.06	6.56

© 2023 Tecumseh Products Company
All rights reserved

1 = cooling capacity 2 = power input 3 = current 4 = condensing temperature 5 = evaporating temperature

(*) Veuillez vous référer strictement aux Recommandations d'Utilisation et Bulletins Marketing Tecumseh du fait de la température de refoulement élevée pour les applications LBP.

(*) Due to very high discharge temperature especially on LBP conditions, please strictly refer to Tecumseh Guidelines & Marketing Bulletin when using this refrigerant.

Nota : Tecumseh se réserve le droit de modifier les informations contenues dans ce document sans préavis.

Note : Tecumseh reserves the right to change information contained in this document without notification.