

PART NO.	MODEL NUMBER	A	B	C	D	E	F	G	MOUNTING KIT	H
497-1559-00	ZF34/41KQE-***	533.6 [21.00]	501.8 [19.75]	277.3 [10.91]	245.7 [9.67]	93.0 [3.66]	93.0 [3.66]	393.3 [15.49]	2	19.1 [0.75]
497-1559-01	ZF49/54KQE-***	551.5 [21.71]	519.5 [20.45]	295.0 [11.61]	263.6 [10.37]	92.6 [3.64]	92.6 [3.64]	441.0 [16.18]	3	33.3 [1.31]

SPECIFICATIONS	
ES NO.	DESCRIPTION
ES92-155	CONVERSION-METRIC

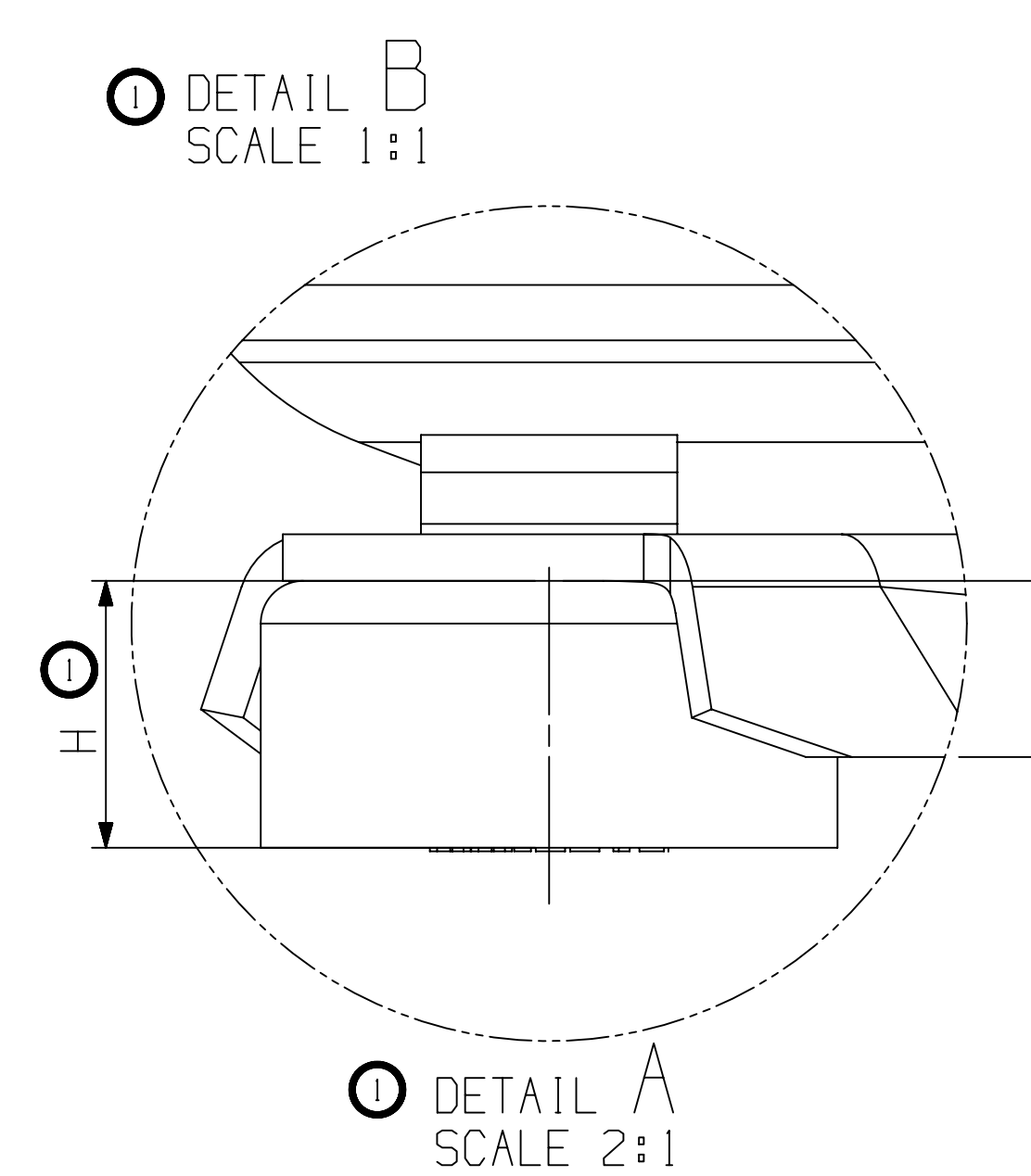

- NOTES:
- 1 ALL TOLERANCES ± 1.5 [0.06] UNLESS OTHERWISE SPECIFIED. DUE TO ACCUMULATED ASSEMBLY TOLERANCES THE LISTED COMPONENTS MAY VARY FROM THE MOUNTING HOLES AS TABULATED.
 - 2 SUCTION FITTING ± 3.0 [0.12]
 - 3 DISCHARGE FITTING ± 3.0 [0.12]
 - 4 MOUNTING KIT: 527-0116-00.
 - 5 MOUNTING KIT: 527-0210-00.
 - 6 4. TUBE ENDS MUST BE PLUGGED.
 - 7 GROUNDING NUT.
 - 8 TORQUE 23-25 Nm [200-220 in Lb]
 - 9 TORQUE 3.6-4.4 Nm [32-39 in Lb]
 - 10 TORQUE 45.5-53.6 Nm [405-475 in Lb]
 - 11 TORQUE 4.5-6.8 Nm [40-60 in Lb]
 - 12 TORQUE 67.8-78.0 Nm [600-690 in Lb]
 - 13 TORQUE 1.0-1.2 Nm [9-11 in Lb]
 - 14 TORQUE 1.4-1.7 Nm [12-15 in Lb]

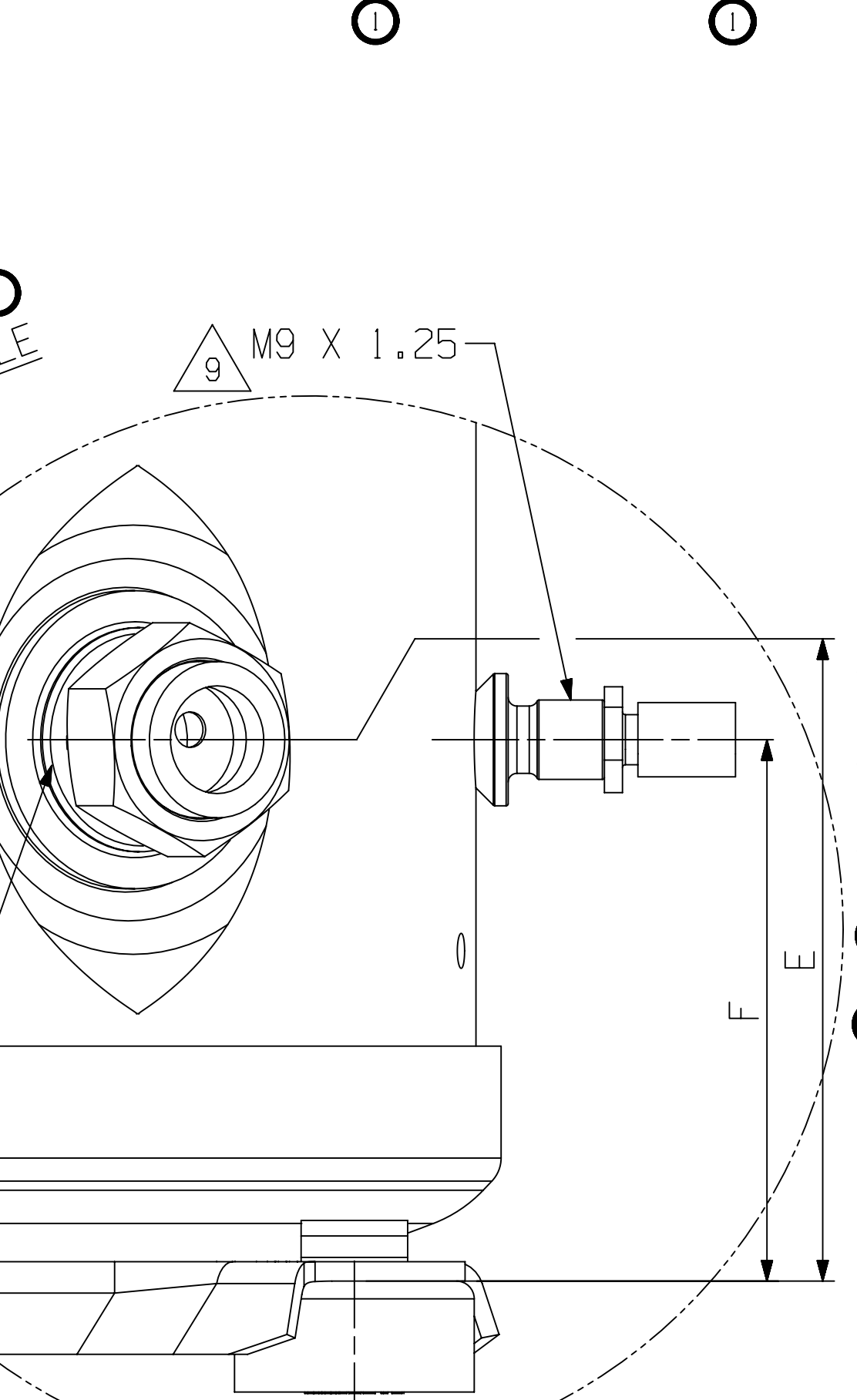
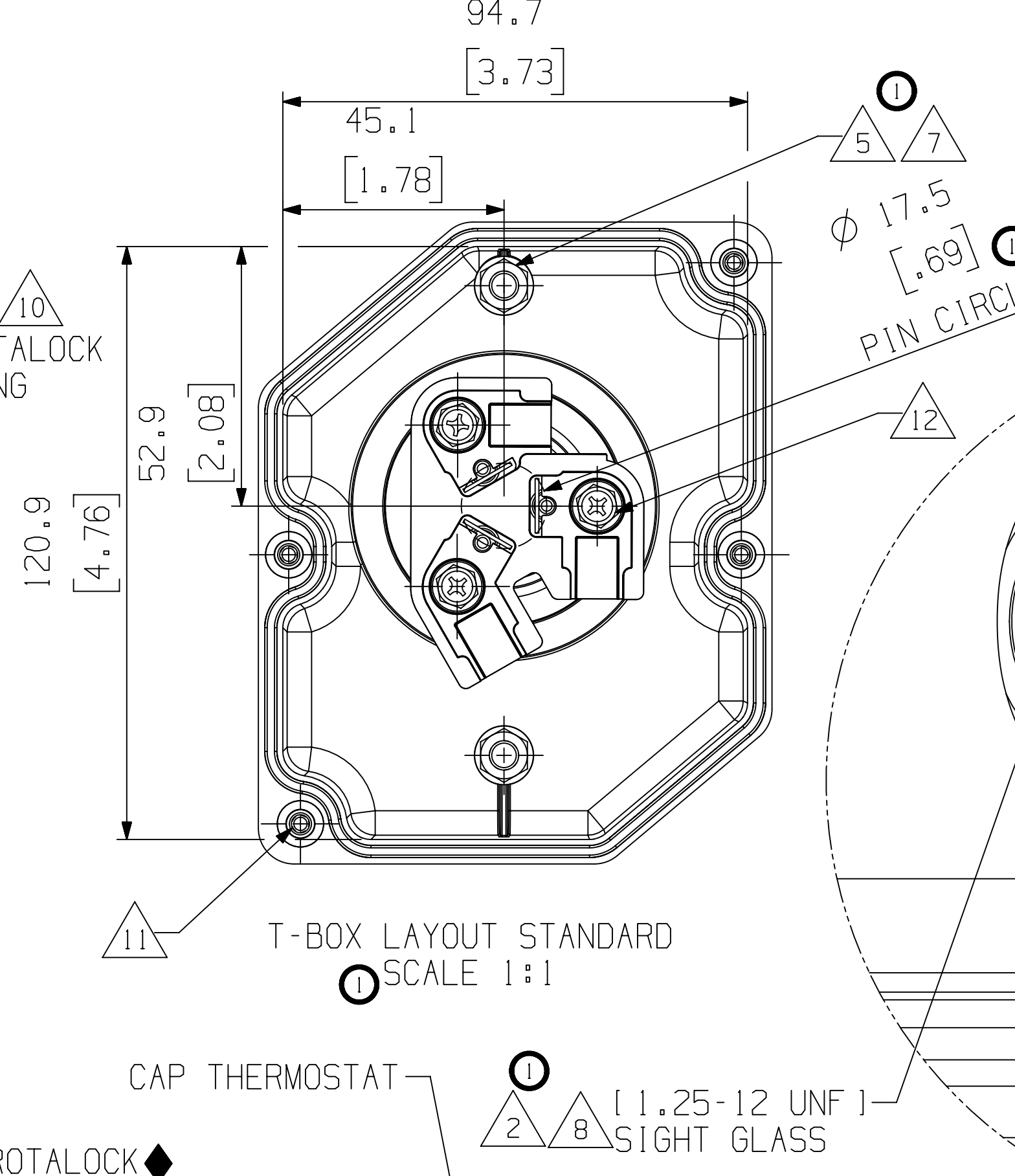
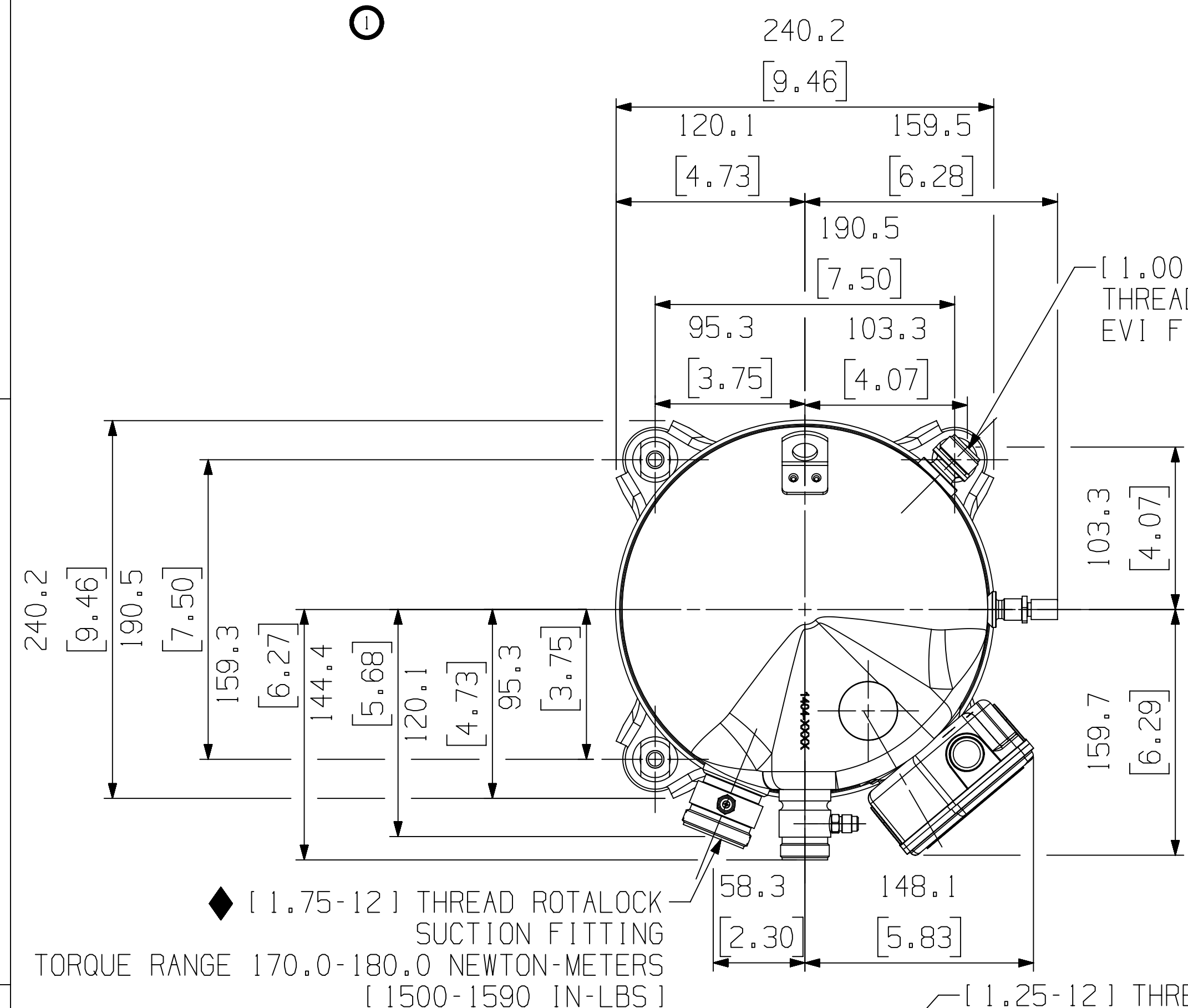
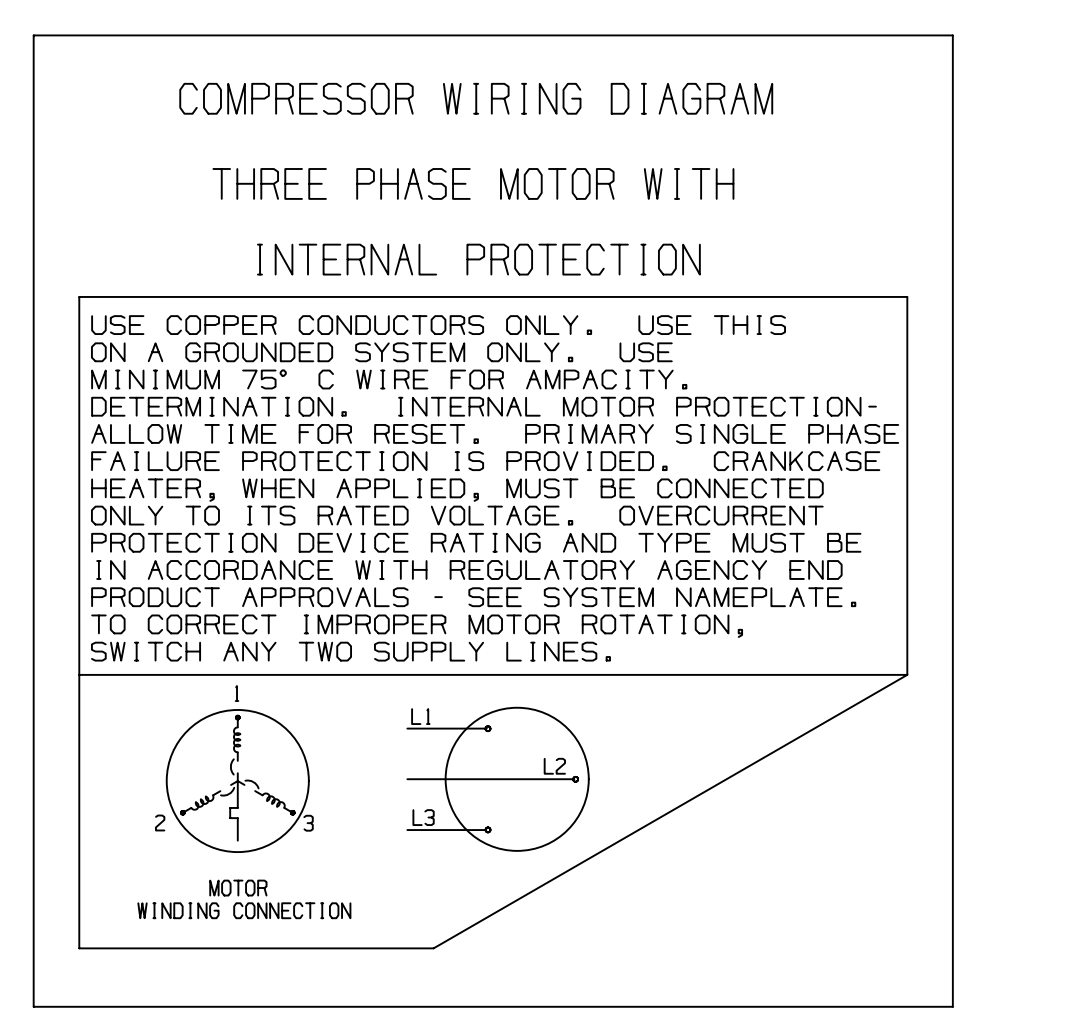
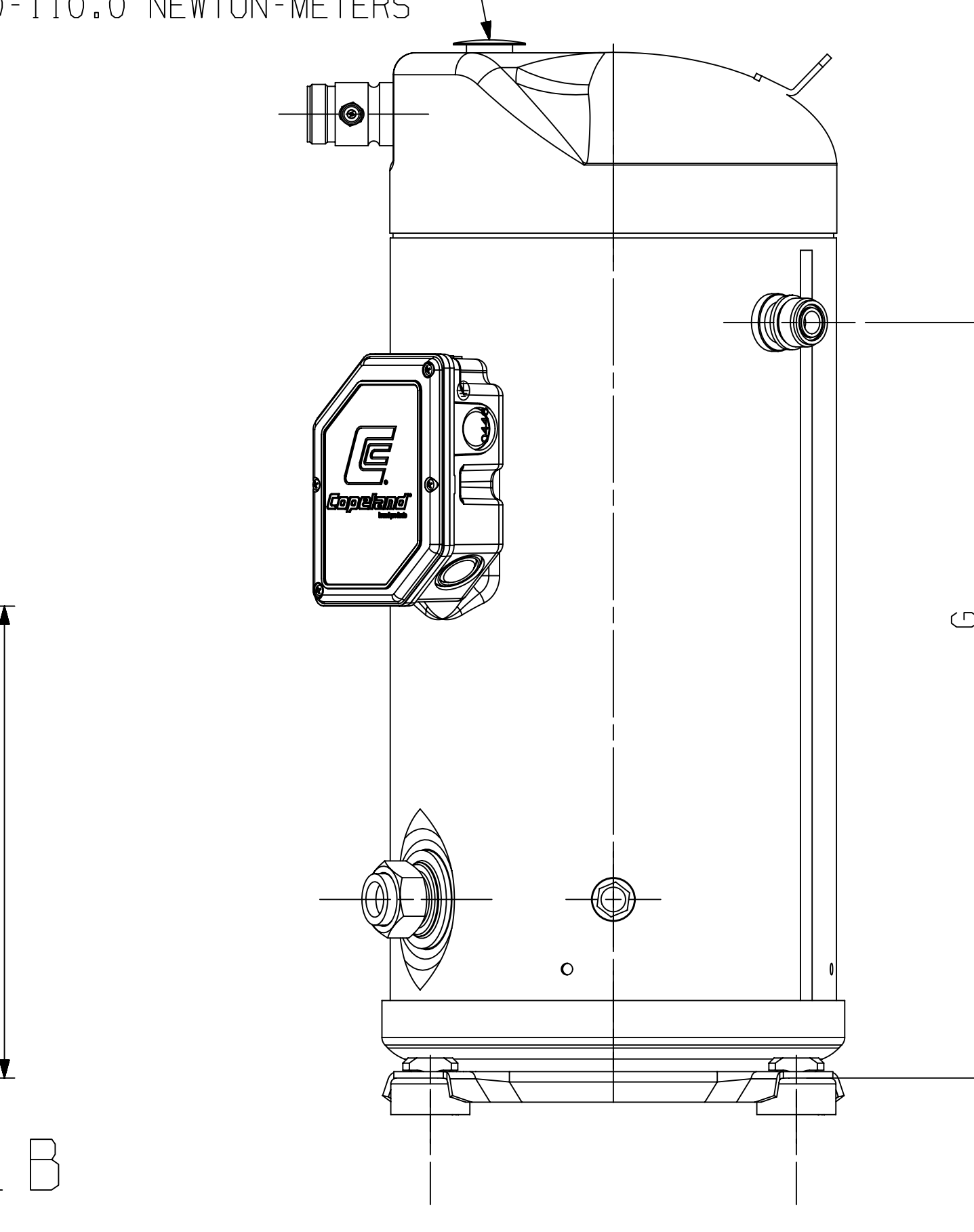
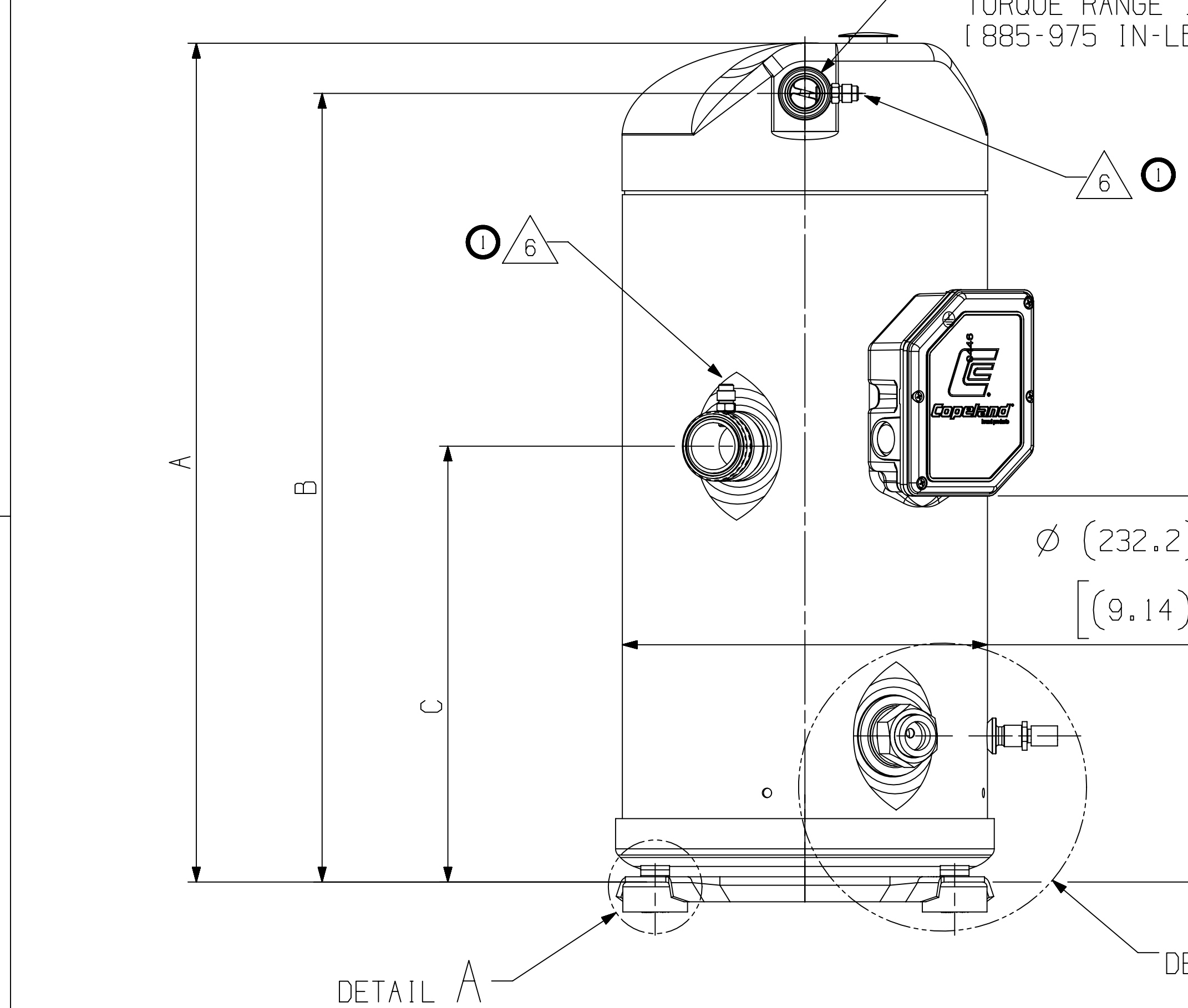

ECN303238	2	ADDED ZF54KQE-*** TO -01	11-1-19	CC	ZH
ECN302358	1	MAKE CORRECTION	06-20-17	SZ	LG
ECN007264	0	RELEASED	07-08-13	SZ	WH
ENG NOTICE NO.	REV. NO.	REVISIONS	DATE	BY	CHKD
15		CONFIDENTIALITY NOTICE			
THIS DRAWING AND INFORMATION CONTAINED HEREIN ARE THE EXCLUSIVE PROPERTY OF EMERSON CLIMATE TECHNOLOGIES, INC AND/OR ITS AFFILIATES (COLLECTIVELY "EMERSON") AND SHALL BE RETURNED UPON DEMAND AND SHALL NOT BE REPRODUCED IN WHOLE OR IN PART, DISCLOSED TO ANYONE ELSE OR USED, WITHOUT THE WRITTEN CONSENT OF EMERSON.					
MATERIAL SPECIFICATION		DRAWN BY	SUPERSEDES DWG NO / REV NO	DATE FORMAT:	
N/A		DATE	SCALE	MM-DD-YY	
		06-19-17	1:1	MM-DD-YY	
TITLE			DRAWING NUMBER	SHEET 1 OF 1	DWG
REF DWG-WELD COMP ASSM			497-1559-00	4	SIZE

EMERSON
Copeland

INTERPRET PER ASME Y14.5M-1994 AND EMERSON DESIGN STANDARDS DS2002

DO NOT SCALE DRAWING

CRITICAL PRODUCT CHARACTERISTICS

UNLESS OTHERWISE SPECIFIED DIMENSIONS ARE MILLIMETER OR (INCH)

TOLERANCES:

- 1-PLACE ±
- 2-PLACE ±
- ANGULAR ±

MODEL NUMBER
ZF49KQE - TFD/TF7-554
ZF54KQE - TFD/TF7-554

SPECIFICATIONS	
ES NO.	DESCRIPTION
ES92-155	CONVERSION-METRIC

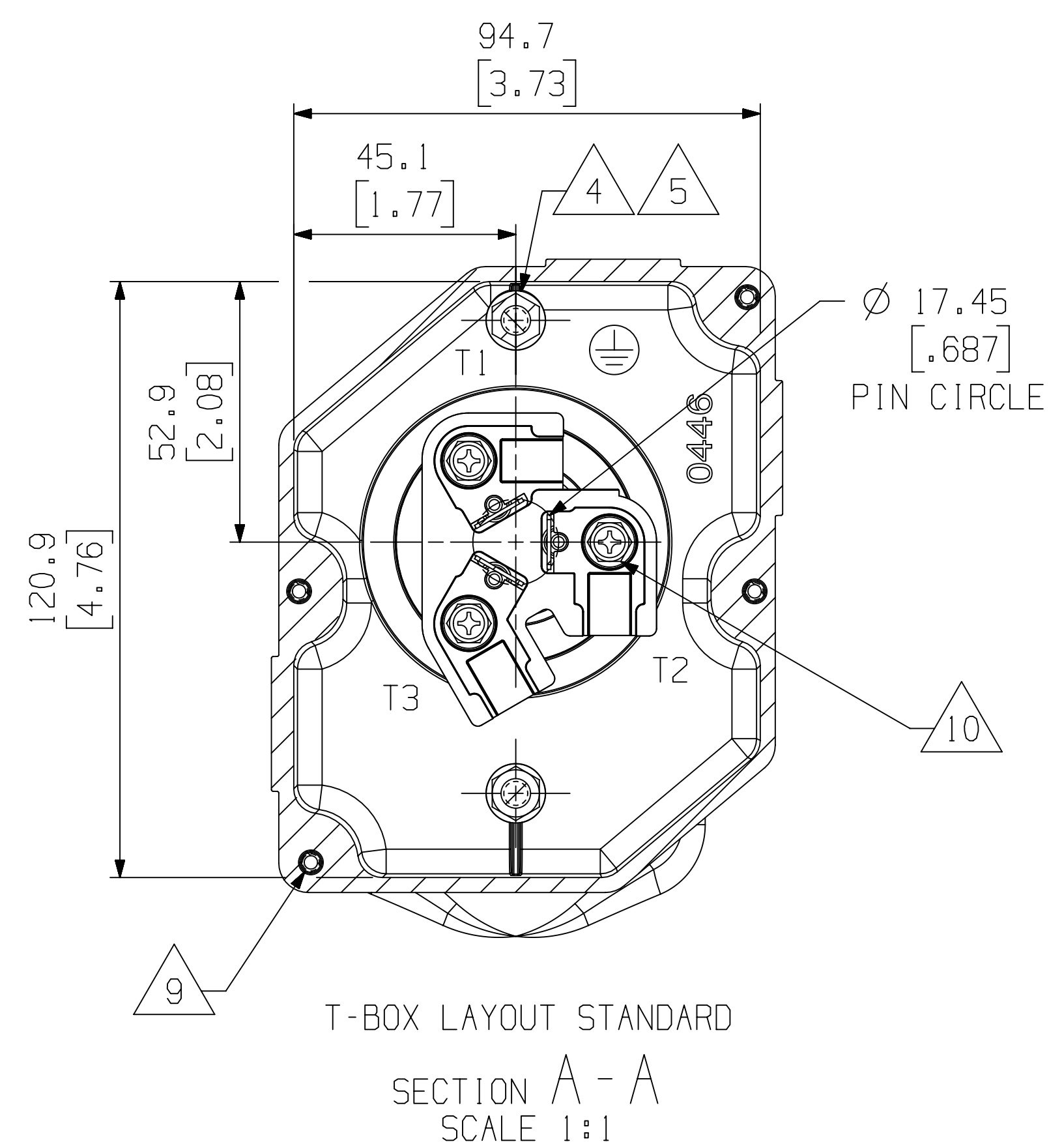
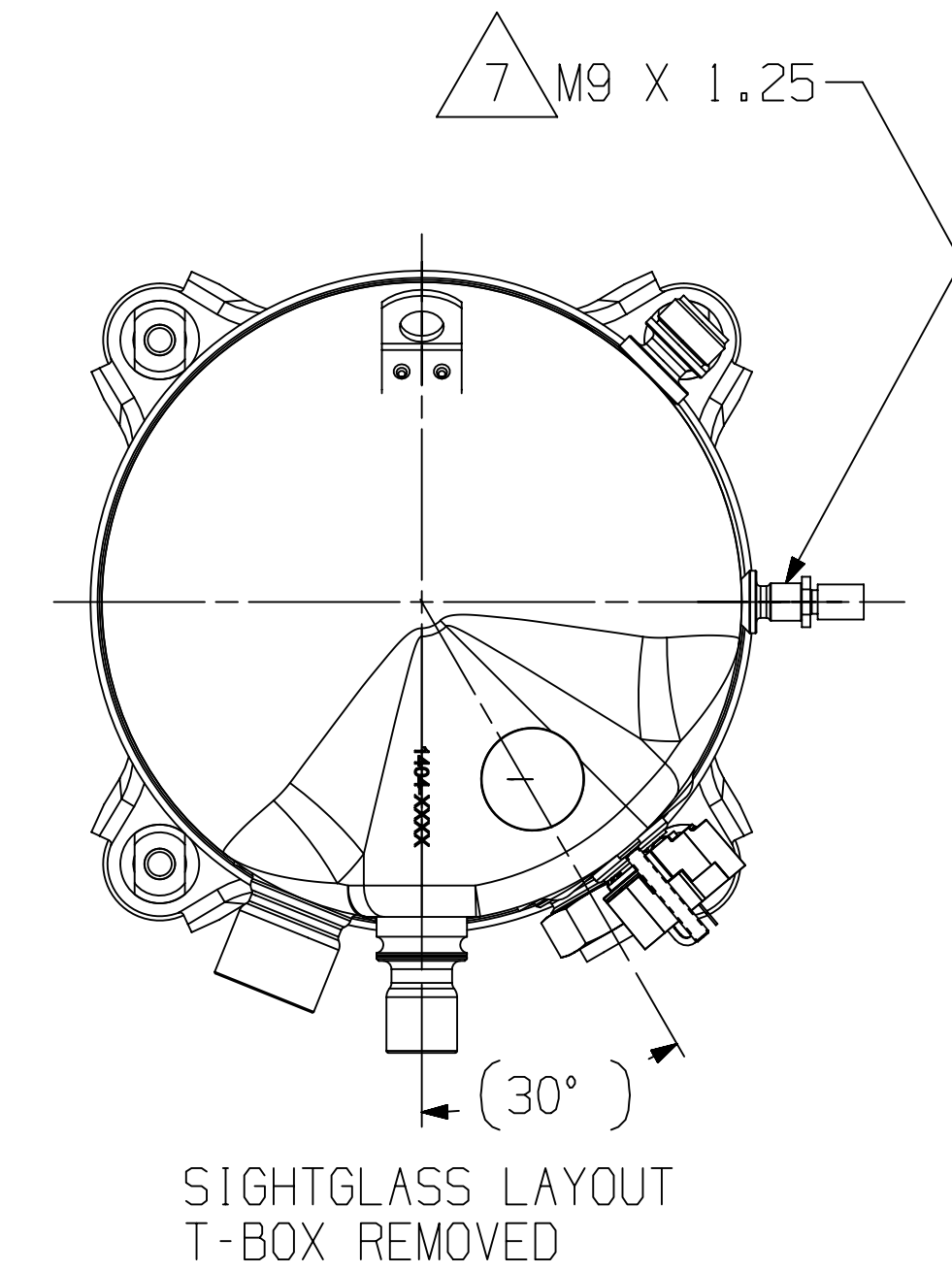
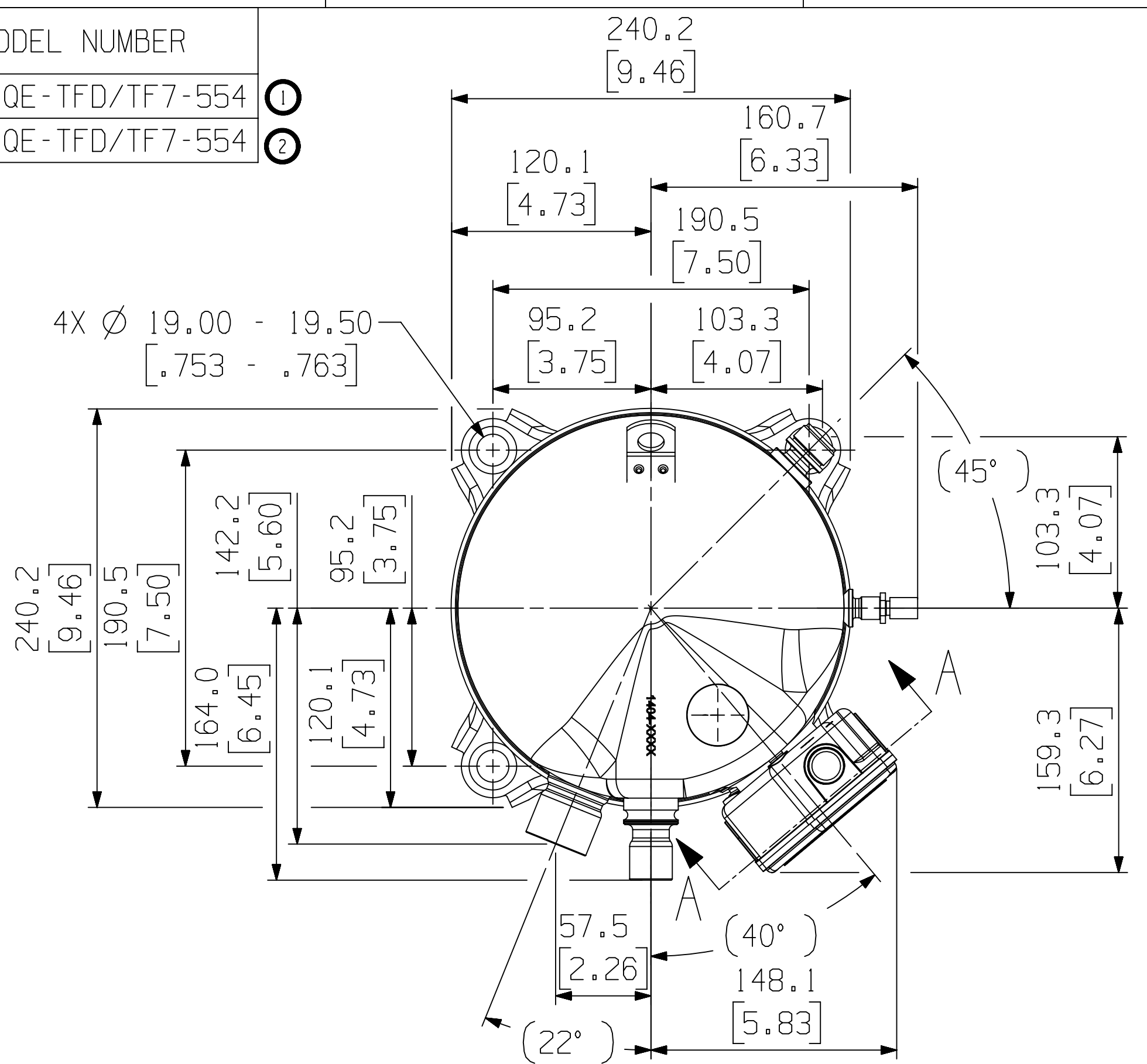

NOTES:

1 ALL TOLERANCES ± 1.5 [0.06] UNLESS OTHERWISE SPECIFIED. DUE TO ACCUMULATED ASSEMBLY TOLERANCES THE LISTED COMPONENTS MAY VARY FROM THE MOUNTING HOLES AS TABULATED.

2 MOUNTING KIT

GROMMET DUROMETER	4 FOOT KIT
55-65	527-0210-00

- ◆ SUCTION FITTING ± 3.0 [0.12]
- ◆ DISCHARGE FITTING ± 3.0 [0.12]
- 3. TUBE ENDS MUST BE PLUGGED.
- 4 GROUNDING NUT.
- 5 TORQUE 3.6-4.4 Nm [32-39 in Lb]
- 6 TORQUE 45.5-53.6 Nm [405-475 in Lb]
- 7 TORQUE 4.5-6.8 Nm [40-60 in Lb]
- 8 TORQUE 67.8-78.0 Nm [600-690 in Lb]
- 9 TORQUE 1.0-1.2 Nm [9-11 in Lb]
- 10 TORQUE 1.4-1.7 Nm [12-15 in Lb]

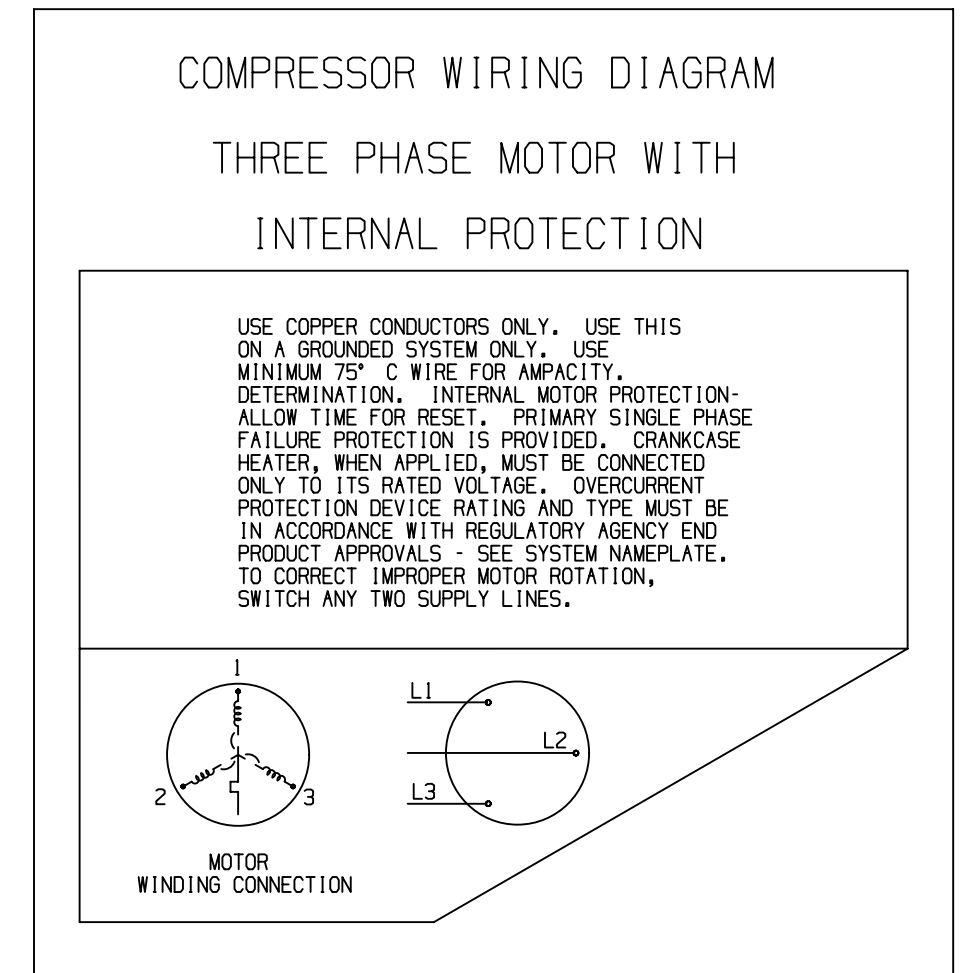
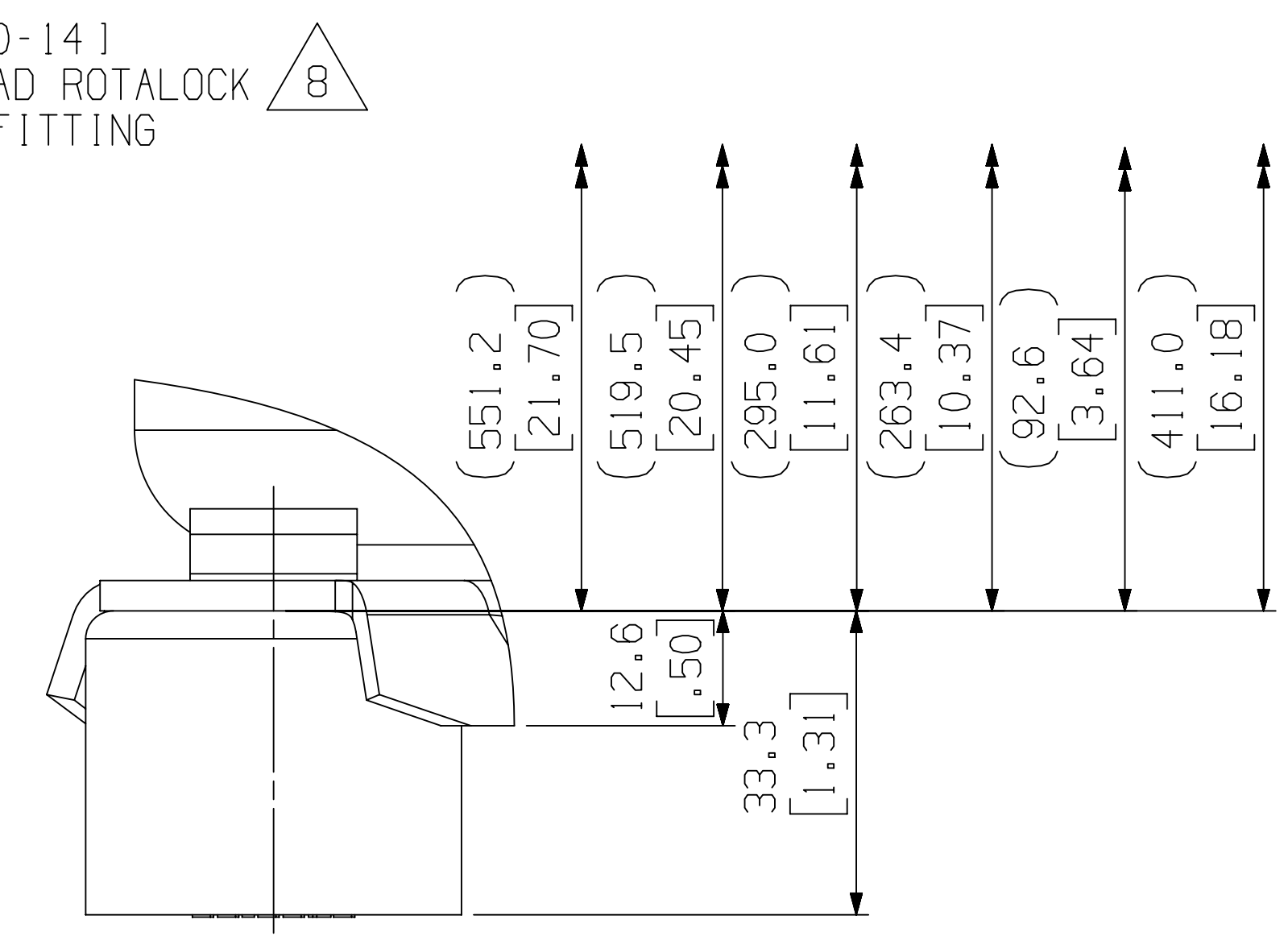
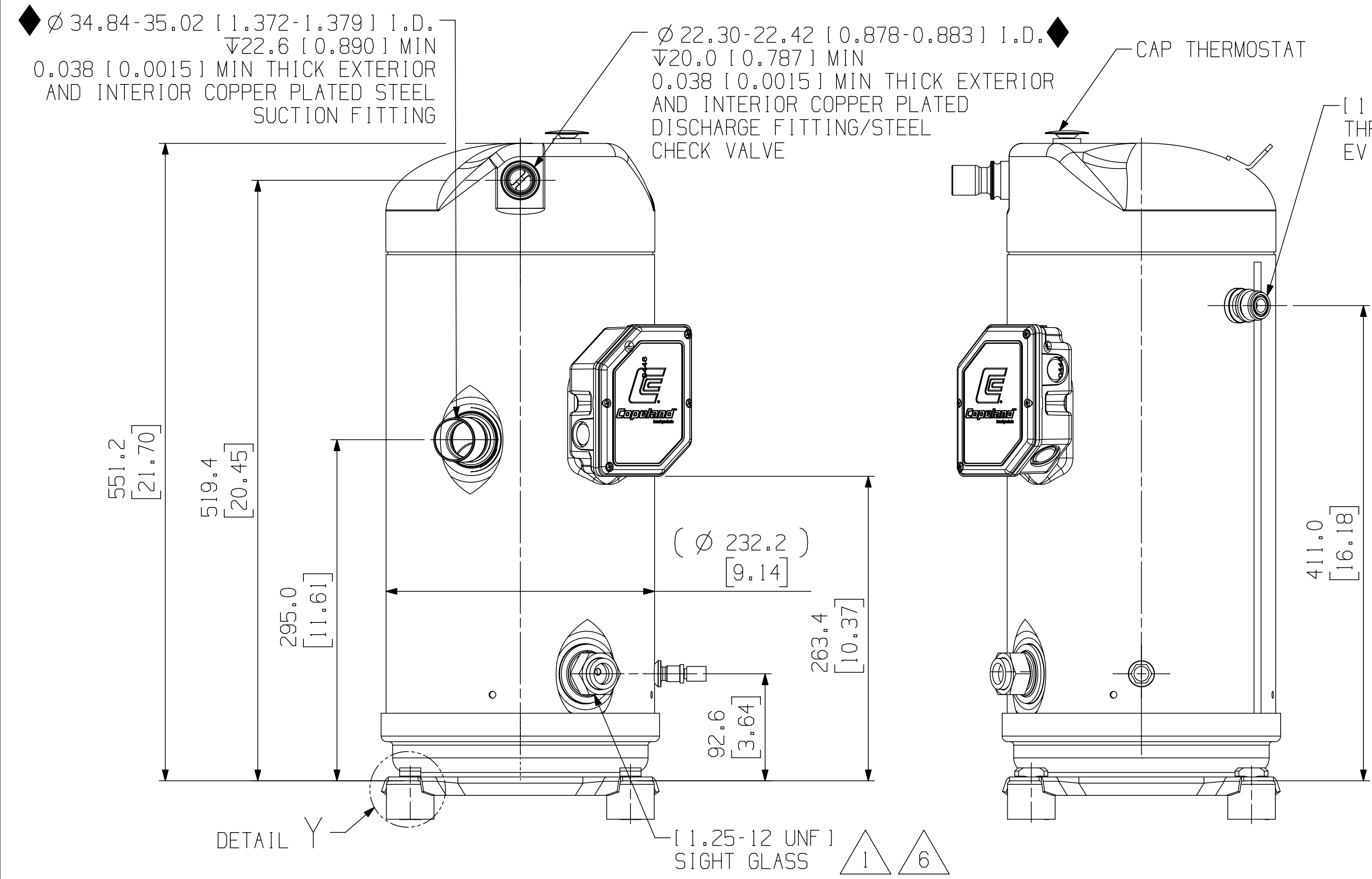

EMERSON
Copeland

INTERPRET PER ASME Y14.5M-1994 AND EMERSON DESIGN STANDARDS DS2002

DO NOT SCALE DRAWING

CRITICAL PRODUCT CHARACTERISTICS

UNLESS OTHERWISE SPECIFIED DIMENSIONS ARE MILLIMETER OR (INCH)

TOLERANCES:
1-PLACE ±
2-PLACE ±
ANGULAR ±

ECN303238	2	ADDED ZF54KQE - TFD/TF7-554	11-1-19	CC	ZH
ECN201363	1	UPDATE MODEL NUMBER	04-17-17	CC	LG
ECN201363	0	RELEASED	09-28-16	AZ	LG
ENG NOTICE NO.	REV. NO.	REVISIONS	DATE	BY	CHKD
15		CONFIDENTIALITY NOTICE			
THIS DRAWING AND INFORMATION CONTAINED HEREIN ARE THE EXCLUSIVE PROPERTY OF EMERSON CLIMATE TECHNOLOGIES, INC AND/OR ITS AFFILIATES (COLLECTIVELY "EMERSON") AND SHALL BE RETURNED UPON DEMAND AND SHALL NOT BE REPRODUCED IN WHOLE OR IN PART, DISCLOSED TO ANYONE ELSE OR USED, WITHOUT THE WRITTEN CONSENT OF EMERSON.					
MATERIAL SPECIFICATION		DRAWN BY	SUPERSEDES DWG NO / REV NO		
N/A		AZ	497-1559-00 / 000		
TITLE		DATE	SCALE	DATE FORMAT: MM-DD-YY	
REF DWG-WELD COMP ASSM		09-28-16	3:8	MM-DD-YY	
			DRAWING NUMBER	SHEET 1 OF 1	DWG SIZE
			497-2930-00		4